



## SURVIVOR SERIES Cylindrical Key-In-Lever Installation Instructions<sup>®</sup>



195



175



170

### DOOR PREPARATION

Figure 1

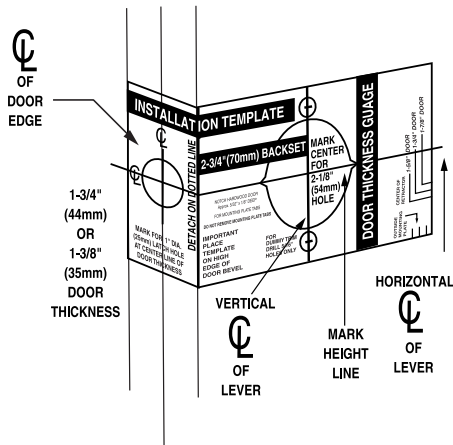
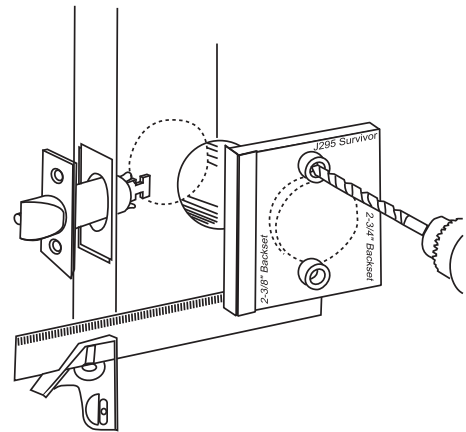

Figure 2



#### DOOR PREPARATION

1. Fold and apply template to high edge of door at desired height from floor.
2. Mark hole centers on door and door edge.
3. Drill 5/16" thru-bolt holes first, then drill 2-1/8" hole.

#### HOLLOW METAL DOORS

1. Must have horizontal and vertical lock and latch support provided by door manufacturer.
2. If 2-1/8" hole exists, use optional Marks J295 Installation Tool to ensure accurate drilling of 5/16" thru-bolt holes.
3. For best results, align the J295 Installation Tool to door and clamp to door before drilling.

Figure 3

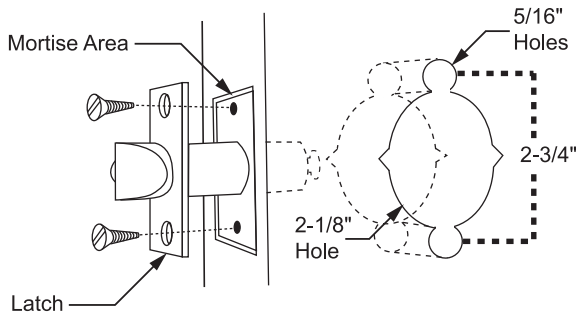

#### INSTALL LATCH

1. Drill 1" diameter hole for latch. Mortise for latch front. Insert latch and fasten with two screws.

**NOTE:** It is important that both 1" and 2-1/8" holes be on the same horizontal center line.

Figure 4

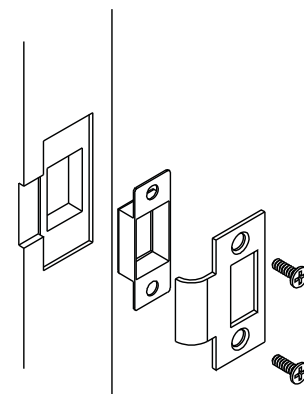

#### INSTALL STRIKE

1. Align strike with latch.
2. Trace strike outline on door jamb.
3. Mortise jamb and install strike and dust box.

## DOOR THICKNESS ADJUSTMENT

1. Locks are factory assembled with a ring for 1-3/4" thick door. Locks can be adjusted for 1-5/8" to 1-7/8" door thickness.  
**To Adjust For Other Door Thickness:**  
Remove outside lever.
2. Before installation, use door thickness gauge on template as shown in Fig. 5, to check lock chassis position. Center of latch retractor should align with mark on gauge for appropriate door thickness. If chassis is not on center, screw chassis in or out to align with mark. **Check that lever engages lever catch before installation. If adjusting for doors thinner than 1-3/4" thickness, split spacer must be removed.**
3. For 1-3/8" doors, adjust for 1-5/8" door thickness then install spacer rings (MARKS #1904 for 195 Series or #1704 for 170 Series, not included; see Fig. 6) on each side of door between roses and door.
4. Reinstall outside lever.

Figure 5

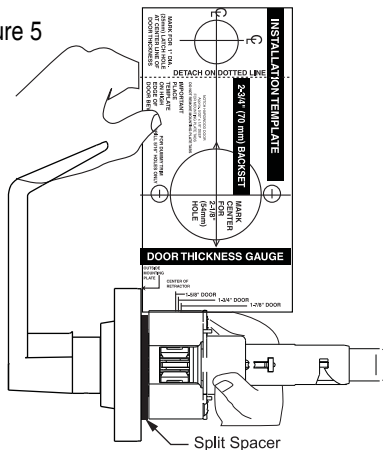

Figure 6

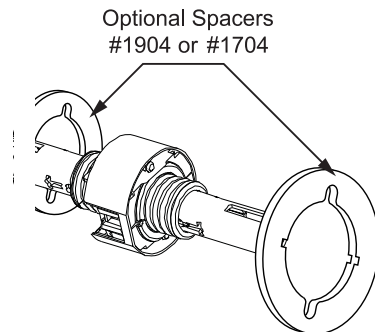

Figure 7

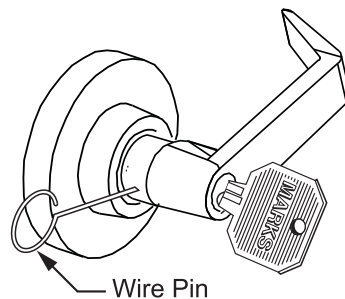
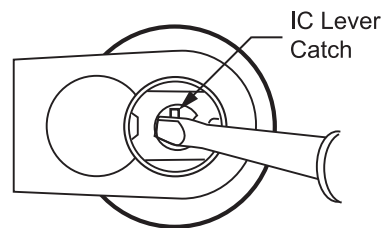

Figure 8



### CONVENTIONAL CYLINDER (Fig. 7):

- A. Turn key in cylinder 45° in either direction.
- B. Depress outside lever catch with wire pin through small hole in rose/lever and pull lever off tube.

### IC CORE CYLINDER (Fig. 8):

1. With IC core removed, use screwdriver inside lever to depress lever latch.
2. Pull off lever.

## REINSTALLING OUTSIDE LEVER

### AB, DA (outside), DW, F and H Functions (Fig. 9):

**NOTE: If lock is not in door, mounting posts must be on vertical center line.**

1. Align lever catch to face latch front.
2. Turn key in cylinder 45° in either direction.
3. Slide lever on tube until it stops at the lever catch.
4. Slightly wiggle and push until the lever engages lever catch and connector.

### S, SB and DA (inside) Functions (Fig. 10):

**NOTE: If lock is not in door, mounting posts must be on vertical center line.**

1. Insert screwdriver in key cam slot, turn fully clockwise. Then, turn back counter-clockwise 90° and remove screwdriver.
2. Turn key in cylinder counter-clockwise 90°. Slide lever on tube with tailpiece aligned properly.
3. Slightly wiggle and push until the lever engages lever catch and connector.
4. Check lock for proper operation before closing door.

### DB Function (Fig. 10):

**NOTE: If lock is not in door, mounting posts must be on vertical center line.**

1. Install inside cylinder. Any orientation in key cam slot is acceptable.
2. Install the outside cylinder as follows:  
Using a screwdriver, place the tip into the key cam slot and turn counter-clockwise as far as possible. When at the maximum counter-clockwise position, turn clockwise 180°. With cylinder in the outside lever, turn key clockwise 90° and install on lever tube.
3. Test to see that timing is correct for inside and outside levers.

Figure 9

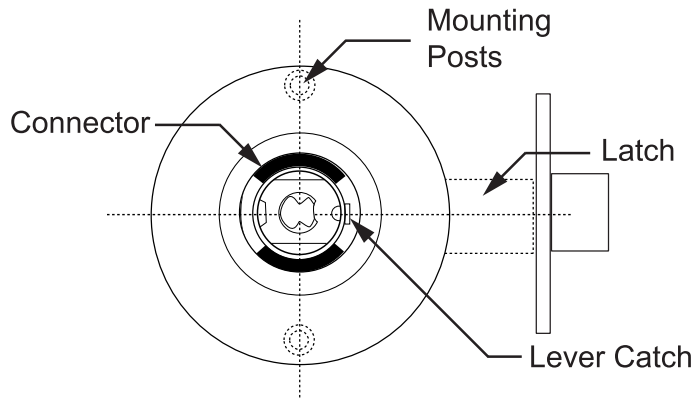
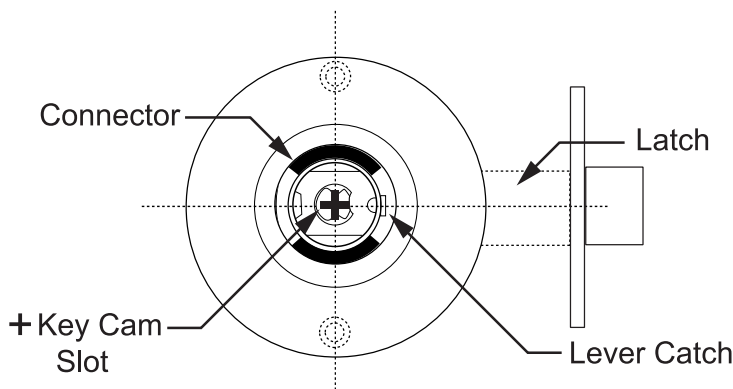

Figure 10



## INSTALLING THE LOCK

### PREPARE LOCK (Fig. 11):

1. Remove inside lever. Depress the lever catch with the wire pin through the small hole in the rose/lever and pull lever off the tube.
2. Depress lever catch again and remove the inside rose assembly.

### INSTALL LOCK (Fig. 12):

1. Push lock through 2-1/8" hole from the outside so that retractor engages latch tail.
2. Prongs must engage inside lock housing.
3. Align outside rose so rose posts enter thru-bolt holes in door.
4. Check from inside of door to see if latch is properly engaged.

### INSTALL INSIDE TRIM:

1. Replace inside rose assembly and fasten to outside rose with the two long thru-bolts.
2. Press rose cover over inside rose. Notch in cover must align with either notch on inside rose.

**NOTE: Be sure stepped plastic washer is between inside rose cover and inside rose before assembling (170 Series ONLY).**

### INSTALL LEVER:

1. Press lever on lock tube, slightly wiggle and push until lever engages lever catch and connector prongs.
2. Test lever to be sure it is on securely.

Figure 11

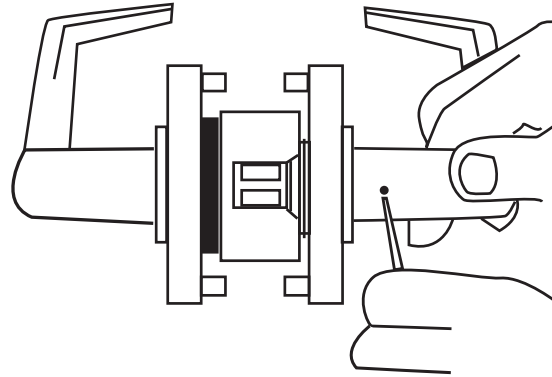
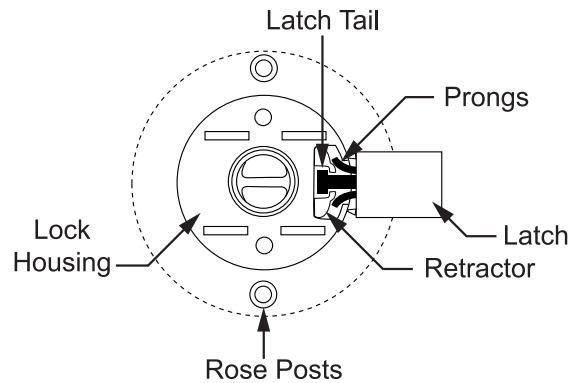

Figure 12



## CHANGE/REPLACE CONVENTIONAL CYLINDER

### CONVENTIONAL CYLINDER: *Removal (all functions)*

1. Remove key from cylinder and pull plastic cylinder retainer from lever, then remove cylinder.

#### *Installation*

1. Tailpiece must be in vertical position in cylinder.
2. Insert cylinder in lever.
3. Press plastic cylinder retainer into lever until flush with base of lever.

#### *T Function*

1. Insert screwdriver in key cam slot and turn fully clockwise without retracting latch. Remove screwdriver.
2. With cylinder in lever handle, insert key and turn clockwise 45°. Slide lever on tube with tailpiece aligned properly.
3. Slightly wiggle and push until lever engages the lever catch and connector.
4. Check lock for proper operation before closing door.

**NOTE: Use MARKS tailpieces only. Lock will NOT function with other tailpiece, (see below). Be sure tailpiece is in a vertical position.**

Figure 13

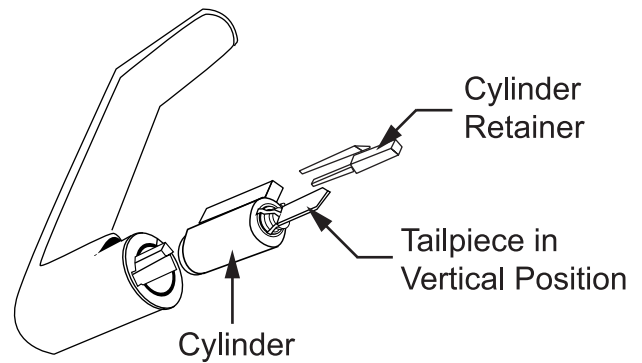

## Cylindrical Lock Tailpieces

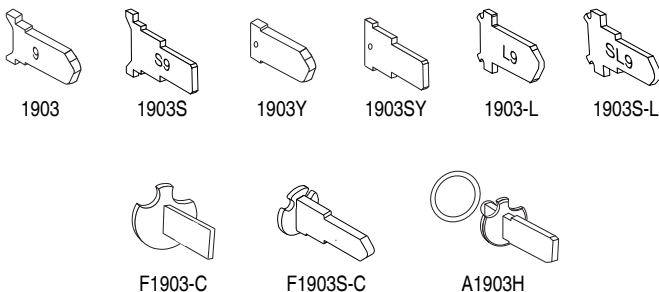

PART #	CODE	FUNCTION	CYLINDER
1903	9	AB, B, DA (ext.), DW, F, FEL, FEU	MARKS 1982
1903S	S9	S, DA (int.), DB, DC, SB, T	
1903Y	—	AB, B, DA (ext.), DW, F, FEL, FEU	YALE 1802
1903SY	—	S, DA (int.), DB, DC, SB, T	
1903-L	L9	AB, B, DA (ext.), DW, F, FEL, FEU	Arrow PK 100C, Ilco 705, Lori 1539, Sargent 13-3266, Abloy, ASSA 65673, 65691
1903S-L	SL9	S, DA (int.), DB, DC, SB, T	
F1903-C	—	AB, B, DA (ext.), DW, F, FEL, FEU	Schlage 23-001, Primus, Corbin-Russwin 2000-034
F1903S-C	—	S, DA (int.), DB, DC, SB, T	
A1903H	H	H	Marks 1982H, Schlage 23-014

# CHANGE/REPLACE IC CORE CYLINDER

## IC CORE CYLINDER: Removal (all functions)

1. Insert control key and turn clockwise, then pull on key to remove core.

## Installation

### AB, DA (outside), DW, F, H Functions

1. Insert control key in core and turn clockwise.
2. Insert tailpiece HR1984 in core.
3. With control key in core, insert core fully into lock.
4. Turn key counter-clockwise and remove key.

### S, SB, DC, DA (inside) Functions

1. Insert screwdriver into key cam slot in tube and turn fully clockwise.
2. Insert control key in core and turn clockwise.
3. Insert tailpiece HR1984S in core.
4. With control key in core, insert core fully into lock.
5. Turn key counter-clockwise and remove key.

## DB Function

1. Using a screwdriver, place the tip into the key cam slot and turn counter-clockwise as far as possible. When at the maximum counter-clockwise position, turn clockwise 90°. Insert outside IC core cylinder into lever.
2. Test to see that timing is correct for both inside and outside levers.

## T Function

1. Insert screwdriver in key cam slot and turn fully clockwise without retracting latch. Now turn counterclockwise 45°. Remove screwdriver.
2. Insert control key in core and turn clockwise.
3. Insert tailpiece HR1984S in core.
4. With control key in core, insert core fully into lock.
5. Turn key counterclockwise and remove key.

Figure 14

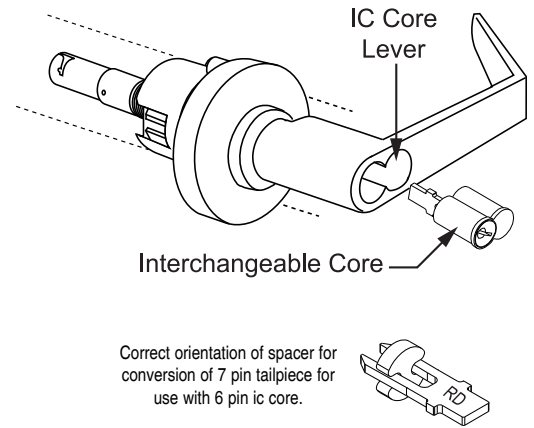

## Cylindrical IC Core Tailpieces

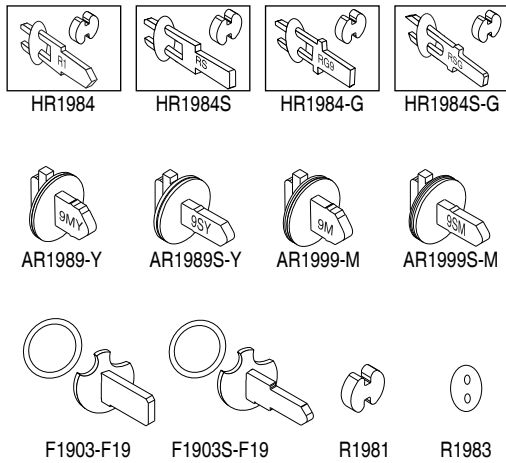

PART #	CODE	FUNCTION	CORE
HR1984	R1	AB, B, DA (ext.), DW, F, FEU, FEL	6 or 7 pin Marks, KSP, Best®, Falcon, Medeco®, Keymark™, Sargent®, Schlage® Small Format
HR1984S	RS	S, DA (int.), DB, DC, SB, T	
HR1984-G	RG9	AB, B, DA (ext.), DW, F, FEU, FEL	6 or 7 pin Corbin
HR1984S-G	RSG	S, DA (int.), DB, DC, SB, T	
AR1989-Y	9MY	AB, B, DA (ext.), DW, F, FEU, FEL	6 or 7 pin Yale
AR1989S-Y	9SY	S, DA (int.), DB, DC, SB, T	
AR1999-M	9M	AB, B, DA (ext.), DW, F, FEU, FEL	Medeco®
AR1999S-M	9SM	S, DA (int.), DB, DC, SB, T	Medeco®
F1903-F19	—	AB, DW, F	6 pin Schlage® Large Format
F1903S-F19	—	S, DA, DB, DC, SB, T	
R1981		Spacer	
R1983		Security Disc	

## TROUBLESHOOTING

PROBLEM	SOLUTION	SEE FIGURE
<b>Levers pull off</b>	1. Lever catch not engaging. Lock may not be centered, or door is too thick.	5
	2. Cylinder retainer not flush.	13
	3. <b>Non-standard sized cylinder: Consult factory.</b>	13
	4. Outside rose located improperly.	12
<b>Unable to assemble outside lever</b>	1. Key orientation incorrect.	11
	2. Outside rose located improperly.	12
<b>Outside lever removable without using key</b>	1. Tailpiece installed in wrong orientation.	10
	2. Wrong tailpiece. <b>See tailpiece chart.</b>	—
<b>Latch won't retract</b>	1. Incorrect retractor/latch engagement or alignment.	13
	2. Poor door preparation or misaligned thru-bolts.	1-3
<b>Key binds in lock</b>	1. Lever catch not fully engaged.	11
	2. Check for proper tailpiece. <b>See tailpiece chart.</b>	—
<b>Key cannot be removed from cylinder</b>	1. Wrong tailpiece alignment.	10
<b>S, SB, DC, DA, DB FUNCTIONS ONLY</b>		
<b>Lever retracts latch in one direction but not other</b>	1. Incorrect installation of cylinder.	13